



Electric Remote Control Application Manual

Actus Manufacturing
245 East Roselawn Avenue
Suite 23
Saint Paul, MN 55117
Main: 651.487.8716
Fax: 651.487.4173

Revision 03
06.2008
001-4900

Table of Contents

TABLE OF CONTENTS.....	ii
CHAPTER ONE - INTRODUCTION.....	1
Important Safety Information.....	1
Power source.....	1
Operating Environment.....	1
ERC (Electric Remote Control) System.....	2
Actuator	3
Electronic Control Module	3
Command Device	4
CHAPTER TWO - DEFINITIONS.....	5
CHAPTER THREE - COMPONENT SPECIFICATIONS.....	7
Actuator	7
Electronic Control Module (ECM).....	11
Joystick/Command Device.....	16
CHAPTER FOUR - SYSTEM INSTALLATION AND DESIGN.....	17
Actuator	17
Electronic Control Module (ECM).....	20
Joystick—Foot Pedal/Command Device.....	20
CHAPTER FIVE - SYSTEM SETUP	23
Proportional System.....	23
Setting Extend and Retract Positions	23
Deadband Adjustment.....	26
Positional system	27
Setting positions.....	27
CHAPTER SIX - TROUBLESHOOTING.....	29
Technical Support	29
Customer Service.....	29
Electric Remote Control Troubleshooting.....	29
Positional System Evaluation.....	30
Proportional System Evaluation.....	33
Actuator Evaluation	36
Command Device Evaluation	36
CHAPTER SEVEN - WIRING DIAGRAMS	37
Actuator Wire Code.....	37
Actuator Wire Code.....	38
CHAPTER EIGHT - WARRANTY.....	39
CHAPTER NINE - APPLICATIONS.....	41

Typical Applications.....	41
Throttle.....	41
Valve.....	43
Pump.....	45
CHAPTER TEN - PARTS LIST	A
Electric Remote Control Parts List	a

Chapter One - INTRODUCTION

Important Safety Information

Note  This section provides you with important safety information on the operation of the ECR® (Electric Remote Control) system. Read the entire section and familiarize yourself with the safety information before proceeding with any work on the ERC system.

The safety operation of the ERC system is grouped into two categories:

- Power source
- Operating environment.

Power source

Danger  **Although the voltage and current levels for the ERC system are relatively small, serious personal injury, death, or substantial property damage may result if the correct procedures are not followed when working on the electrical portion of the system.**

When working with any ERC system, take the following precautions:

- Become familiar with the wiring, switches, and measuring points on the ERC system.
- Wear approved eye protection, particularly if working on or around batteries.
- Remove all jewelry.
- Always measure for voltages from junction boxes and conductors to ground. Whenever, possible, work with one hand.
- Never assume that switches and disconnects always work and thus current is not flowing.
- Use approved insulated tools.

Operating Environment

Caution  **The ERC system may operate in environments where it is necessary to be aware of other safety issues that relate to that environment.**

Additional safety issues that Actus recommends should be observed while working on the ERC system include:

- Never work on the system when the floor is covered with water.
- Moving parts and protruding edges associated with application may cause injury.
- Shut down and lock out application while ERC system is being serviced or maintained.

ERC (Electric Remote Control) System

The Actus ERC is a control system that is designed to replace a mechanical linkage with an electromechanical system. The system provides fast, precise control of remote functions on applications as diverse as engine throttle control, hydraulic spool valve operation, and variable volume pump positioning.

The ERC system allows an operator to control the application remotely from a single, or multiple location(s). Any change in the command signal by the operator will result in a corresponding change in the actuator rod position.

The most notable advantage of the ERC system over mechanical systems is that in case of an emergency or power failure, the ERC system will return to a predetermined safe position (i.e., idle on a throttle application or center on a spool valve).

The typical Actus ERC system consists of three basic components (see figure 1-1):

- Electromechanical Linear Actuator
- Electronic Control Module (ECM)
- Command Device

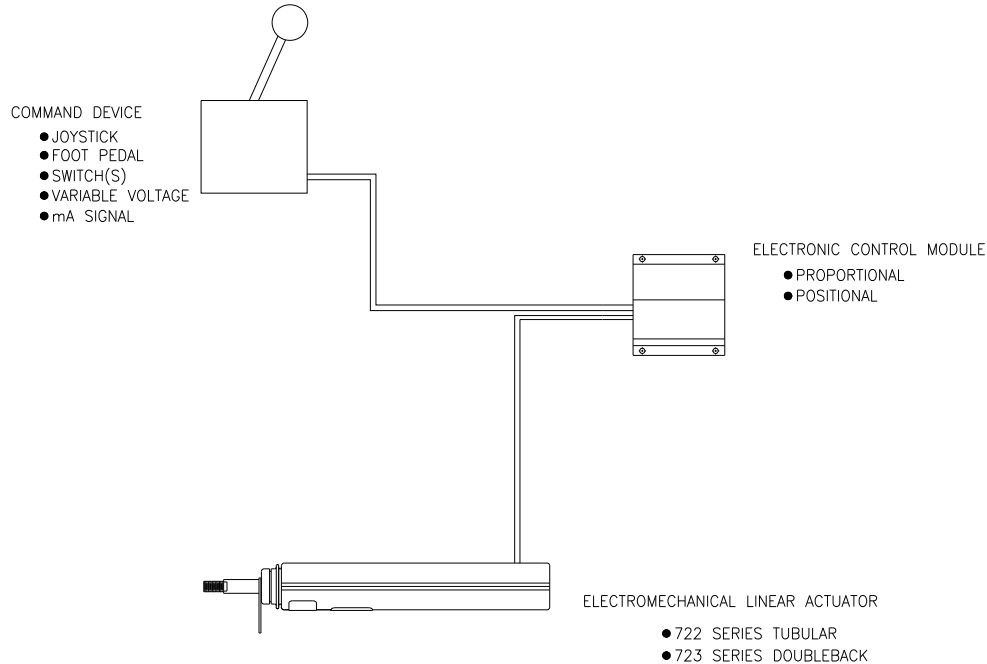

Figure 1-1. ERC System Diagram

Actuator

The heart of the ERC system is the actuator. It uses a 12Vdc brush type motor driving through a gear reduction to an electromagnetic clutch. When power is applied to the clutch and motor, the output shaft moves back and forth over its three inches of travel. A linear potentiometer inside the actuator is the feedback device providing the actuator rod position to the ECM at all times.

Two actuator modules are available:

- 722 Series (Tubular) – 30-lb load – (***Holding Force***)
- 723 Series (Doubleback) – 60-lb load – (***Holding Force***)

Electronic Control Module

The brain of the system is the electronic control module (ECM). It compares an input signal (voltage) from the command device to the feedback signal (voltage) from a device located in the actuator. If the signals are equal, there is no actuator movement. If they are not equal, the controller provides power to the motor, driving the output shaft either in or out until the feedback and command signals are equal.

The ECM continually monitors the entire system while it is operating. If an error occurs in any of the system components or wiring, the ECM safely shuts down the system.

Two models of electronic ECM are available:

- Positional – up to five user defined positions
- Proportional – infinitely variable control over the full 3 inches of actuator stroke

Command Device

In the Proportional System, the command device is typically hand or foot operated (for example, joystick or foot pedal). Usually the control portion of the command device is a 10K ohm potentiometer (pot). If desired, any 10K ohm pot may be used as a substitute (for example, a rotary pot on the instrument panel). See Chapter 3 “Component Specification” for other command pot options.

In the Positional System, the operator selects, normally via a switch or switches, one of up to four preset “electronic” positions. The four positions are set by adjusting each of the four trimmer pots, which are located on the ECM. The input switch or switches are used to select one of the pots to be used for the input signal (voltage). The fifth position is the “float” position that can be set by using an external spring. (For example, the “float” position is selected when the clutch is released by a system error, or when power is turned off).

Chapter Two - DEFINITIONS

Actuator

A mechanism that provides the moving force in a motion control system.

Clutch

A coupling device used to connect and disconnect a driving and a driven part of a mechanism.

Command device

An operator controlled device (see also joystick) which transmits the desired system response/operation to the ECM (see also control module/controller).

Electronic Control Module (ECM)

A device that compares an input signal from the command device to the feedback signal from the actuator and drives the actuator until the two signals are the same.

Electromechanical

A mechanical process or device actuated or controlled electrically.

Electric Remote Control (ERC)

An Actus system consisting of an actuator, ECM and command device. Used for electrically remote controlling a mechanical operation such as stroking a pump, valve or throttle.

Feedback

The return to the input of a part of the output of a machine, system or process as for producing changes in an electronic circuit that improve performance or in an automatic control device that provide self-correcting action.

Joystick

An input device that is capable of motion in two or more directions and used to transmit the desired system response/operation to the control module (see also Electronic Control Module).

Light Emitting Diode (LED)

A plastic encapsulated semiconductor device which emits light when current flows through it.

Load

The maximum continuous push/pull or hold force.

Motor

A rotating mechanism, in the actuator, that transform electrical energy to motion.

Output Rod

The external moving portion of the actuator—connecting actuator motor to the load.

Peak Load

The maximum momentary load.

Potentiometer (Pot)

A variable resistor device used as a position indicator (for example, actuator output rod position, command input, etc.).

Trimmer Potentiometer (Trim Pot)

Special multi-turn potentiometer which allows for fine adjustments.

Chapter Three - COMPONENT SPECIFICATIONS

Actuator

In the Actus ERC System the actuator is the component in which an electrical input from the ECM is converted into a mechanical output. Depending on the model, the actuator is capable of either 30 or 60 lbs of load at a speed of 3 inches/second in the 30-lb unit and 1 ½ inches/second in the 60-lb unit. The stroke can be infinitely adjusted from 0 to 3 inches.

A sealed 10K ohm feedback pot in the actuator provides a constant signal (voltage) to the electronic control module (ECM). Using this signal, the ECM knows the position of the output rod at all times. The ECM compares the signal from the actuator pot to the command signal. If the signals do not match, the ECM provides 12 Vdc to the actuator motor, which drives the output rod until the signals match. The direction of rod movement depends on the polarity of the voltage to the motor.

The 12 Vdc electromagnetic clutch in the actuator remains engaged under normal operating conditions. The clutch will disengage when power is removed as a result of intentional shutdown, electrical failure, or an error signal. If desired, an external spring can be used to return the load to a desired position (i.e., idle on a throttle application).

The components of the actuator are housed in a compact, weatherproof, die cast aluminum housing. The table below provides information about the actuator.

Actuator		
Parameters and Characteristics	722 Series Model	723 Series Model
Volts (see note):	12 volts nominal	12 volts nominal
Output Force (Holding Load):	30-lbs @ 3 amp	60-lbs @ 3 amp
Output Force (Dynamic Load):	90-lbs	150-lbs
Motor current (at rated load):	2.25 amps	2.25 amps
Motor locked rotor current:	18 amps	18 amps
Clutch current:	0.6 amp	0.6 amp
Stroke (max):	3 inches	3 inches
Maximum no load speed:	3 inches/second	1.5 inches/second
Weight:	2.4-lbs	3.6-lbs
Operating Temp Range:	-40°F (-40°C) to + 158°F (70°C)	
Operating voltage range:	11.5 to 16.0 Vdc	

Actuator

Parameters and Characteristics

722 Series Model

723 Series Model

Continued

Construction:

- Aluminum die cast housing
- E-coated for corrosion resistance
- Permanently lubricated metal gear drive
- Stainless steel output shaft
- Sealed construction
- Dust proof and splash proof
- Polypak rod seal
- 4-start stainless steel Acme screw

Cable:

7-wire, 20-gauge, shielded cable, 3 feet long

Options:

Electric cable connector
Mounting Hardware



Note

1. If system voltage is other than 12 Vdc nominal, use a power converter to provide proper voltage. For more information, contact your Actus representative.
2. **If voltage drops below 12 Vdc, actuator will continue to operate at a decreased performance level. At 10.3 Vdc, the ECM shuts down, and the clutch will be disengaged—resulting in the actuator output rod floating freely.**

See figures 3-1, 3-2, and 3-3 for the actuators' dimensional and mounting information.

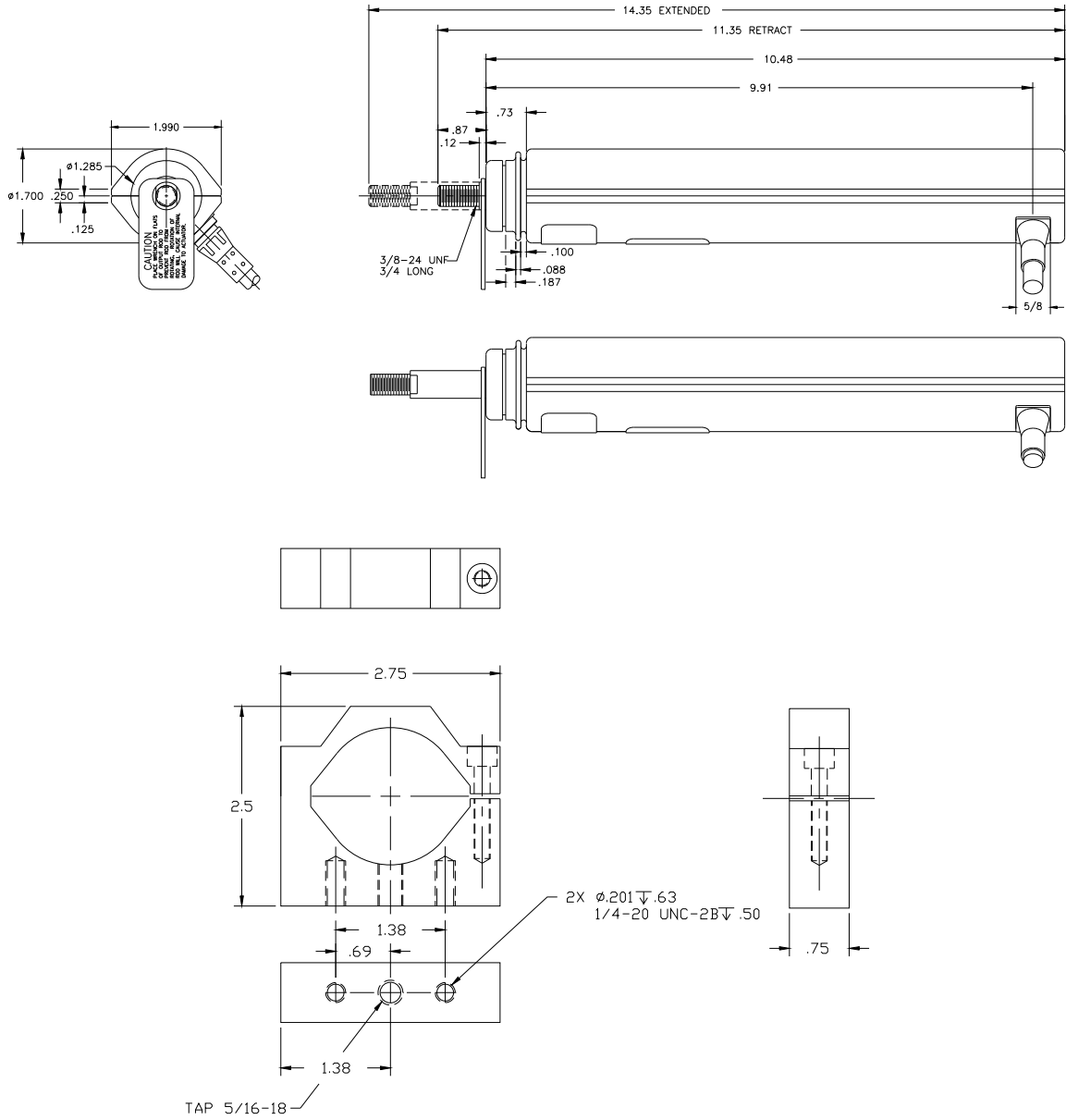

Figure 3-1. 722 Series Actuator with Mounting Clamp (dimension in inches)

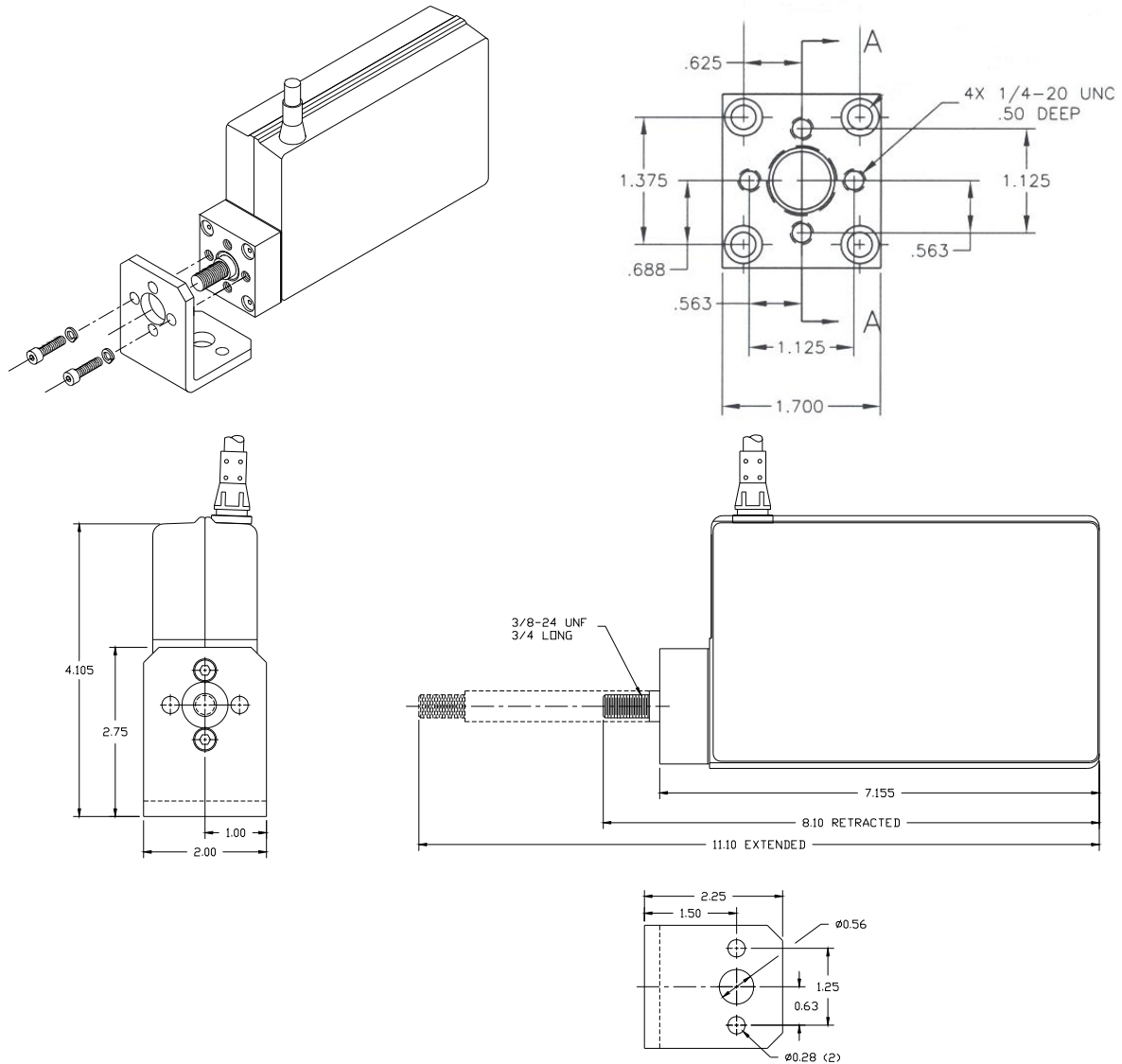

Figure 3-2. 723 Series Actuator with Mounting Bracket (dimensions in inches)

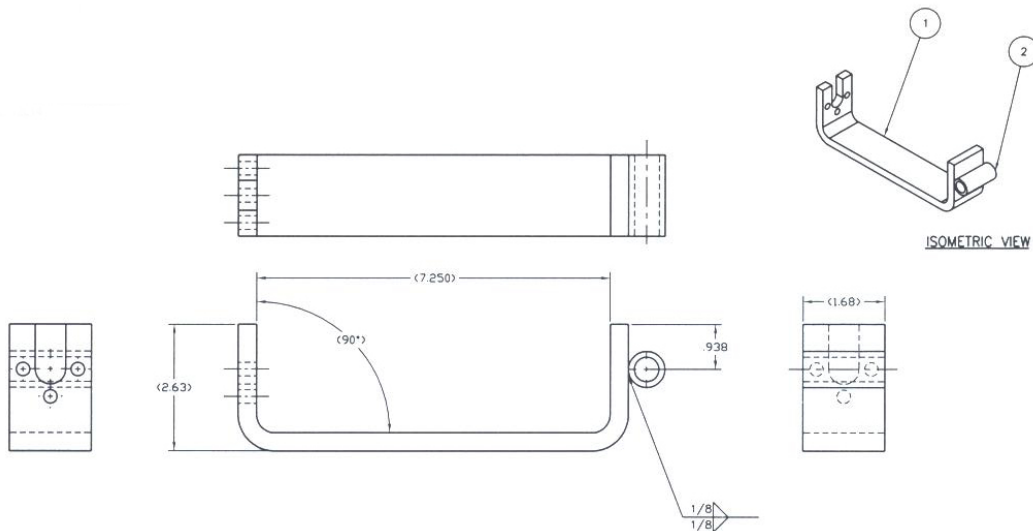

Figure 3-3. 723 Series ERC Trunion Mounting Bracket (dimensions in inches)

Electronic Control Module (ECM)

The ECM monitors the system and uses information provided by the operator via the command input to control the movement of the actuator. When the command input is changed, the controller will engage the actuator motor and drive the rod until the signal from the feedback pot in the actuator matches the command signal. When the signals are equal, the clutch will hold the actuator rod fixed in the new position until the command input changes.

The ECM monitors the system to control the engage/disengage feature of the electromagnetic clutch. Under normal operating conditions, the clutch is engaged to allow movement of the load. However, if a loss of signal from the actuator or command device occurs, the clutch will be immediately disengaged, allowing the output shaft to float freely. Another clutch safety circuit monitors the movement of the actuator. If the position feedback signal from the actuator does not match that of the command device within five seconds, the clutch will be released.

After disengaging due to the above faults, the clutch will not re-engage until the operator matches the command and feedback positions (signals) or input power to the ECM is cycled. An additional safety circuit shuts off the motor whenever the clutch is disengaged. This prevents unnecessary motor wear.

Because system operation may become unpredictable at low voltages, the ECM monitors the system voltage and will shut down the system when the voltage drops below 10.3 Vdc. A built in delay before the low voltage shutdown circuit becomes active allows the voltage to drop below 10.3 Vdc for a short period of time at system start-up. The delay accounts for the drop that may occur in the system voltage when the engine starter is engaged.

If a low voltage error occurs, the input power to the ECM must be cycled to reset the system.

To aid in the setup and troubleshooting of the ERC system, four diagnostic Light Emitting Diodes (LED's) are located in the ECM next to the trim pots (see Chapter 4 "System Setup" and Chapter 6 "Troubleshooting" for more information).

When using an ECM, other than Actus design, it is important to incorporate safety features to protect the operator, equipment and actuator.

The ECM is enclosed in an aluminum extrusion and encapsulated in a potting compound to completely protect the module from harsh environmental conditions. The extrusion also acts as a heatsink to remove heat from the power electronic components. The table on the next page provides information about the ECM.

Proportional ECM

Parameters and Characteristics

Provides fully proportional control of one actuator.

Control type:	Fully Proportional
Voltage input (see note):	<ul style="list-style-type: none"> • 12 Vdc nominal • 10.3 Vdc minimum • 16.0 Vdc maximum
Motor output:	12 Vdc, 5 amp (current limited)
Clutch output:	12 Vdc, 1 amp maximum
Temperature range:	-40°F (-40° C) to 185°F (85°C)
Adjustment features	<ul style="list-style-type: none"> • Extend Stroke position • Retract Stroke Position • Dead band (Sensitivity)
Actuator control harness:	7 wire, 20 gauge shielded cable, 6 feet long; connector optional
Command harness::	3 wire, 20 gauge shielded cable, 3 feet long
Power harness:	2-wire, 18-gauge, 3 feet long, individual wires
Construction:	Extruded aluminum housing. Electronics potted to protect against environment and shock



Note

1. If system voltage is other than 12 Vdc nominal, use a power converter to provide proper voltage. For more information, contact your Actus representative.
- 2. If voltage drops below 12 Vdc, actuator will continue to operate at a decreased performance level. At 10.3 Vdc, the ECM enters error condition and shuts down outputs to motor and clutch.**

See figure 3-4 for proportional ECM dimensional information.

See figure 3-5 for proportional ECM monitor (LEDs)/control (pots) and interconnect cabling information

See figure 7-2 for proportional ECM wiring information.

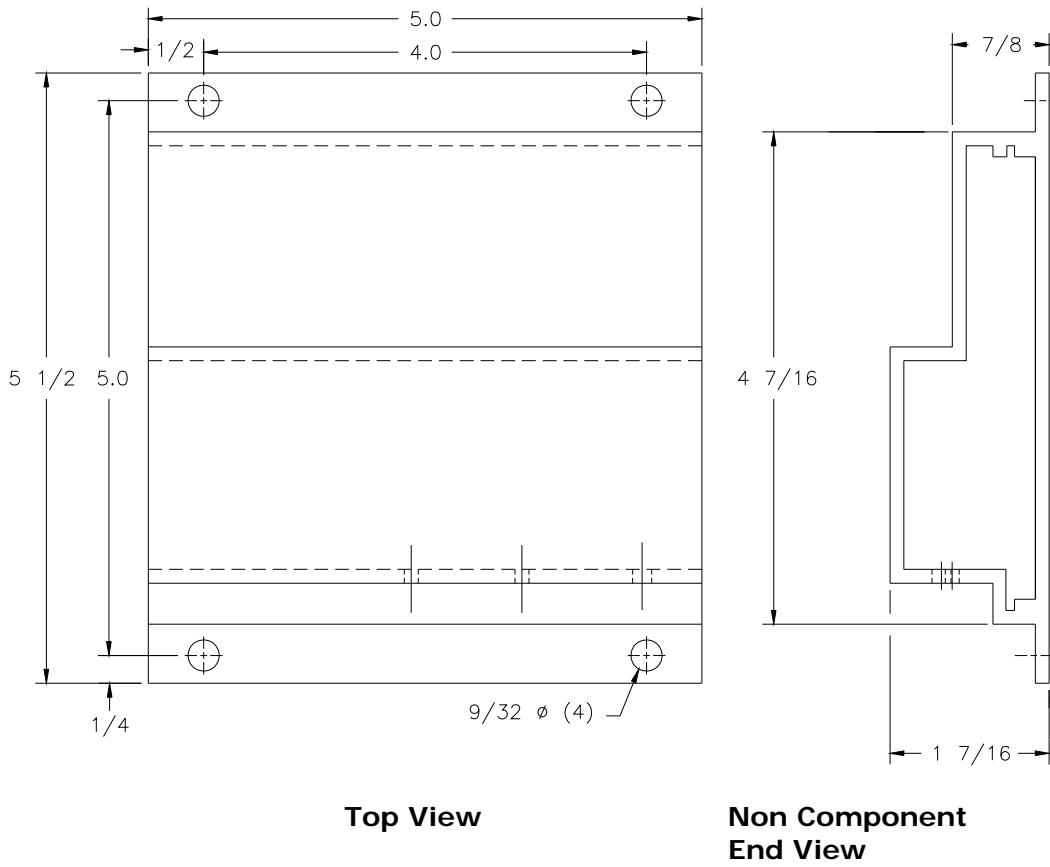

Figure 3-4. Proportional ECM (dimensions in inches)

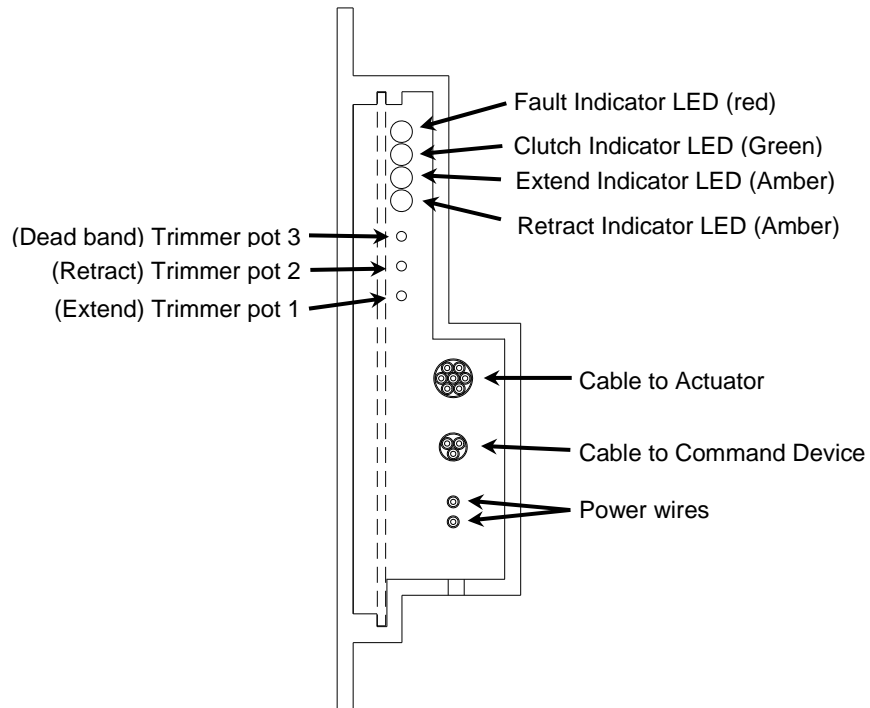

Figure 3-5. Proportional ECM (component end view)

Positional ECM

This is a five-position ECM. When used with selector switches (double pole-double throw) or some other combination giving this function, it commands the actuator to go to one of four preset positions. The fifth position is realized with power off to the ECM which disconnects the clutch and removes power to the motor, allowing a spring, or similar device to move the output shaft to a desired position —normally idle on a throttle or neutral on a valve or pump.

Characteristics and Parameters

Control type:	Five position
Voltage input (see note):	<ul style="list-style-type: none"> • 12 Vdc nominal • 10.3 Vdc minimum • 16.0 Vdc maximum
Motor output:	12 Vdc, 5 amp maximum
Clutch output:	12 Vdc, 1 amp maximum
Temperature range:	-40°F (-40° C) to 185°F (85°C)
Adjustment features:	<ul style="list-style-type: none"> • Position 1 (trim pot) • Position 2 (trim pot) • Position 3 (trim pot) • Position 4 (trim pot)
Actuator control harness:	7 wire, 20 gauge shielded cable, 6 feet long; (connector optional)
Power or command harness:	3 wire, 20 gauge shielded cable, 3 feet long
Construction:	Extruded aluminum housing. Electronics potted to protect against environment and shock



Note

1. If system voltage is other than 12 Vdc nominal, use a power converter to provide proper voltage. For more information, contact your Actus representative.
2. **If voltage drops below 12 Vdc, actuator will continue to operate at a decreased performance level. At 10.3 Vdc, the ECM enters error condition and shuts down outputs to motor and clutch.**

See figure 3-6 for positional ECM dimensional information.

See figure 3-7 for positional ECM monitor(LEDs)/control(pots) and interconnect cabling information.

See figure 7-1 for positional ECM wiring information.

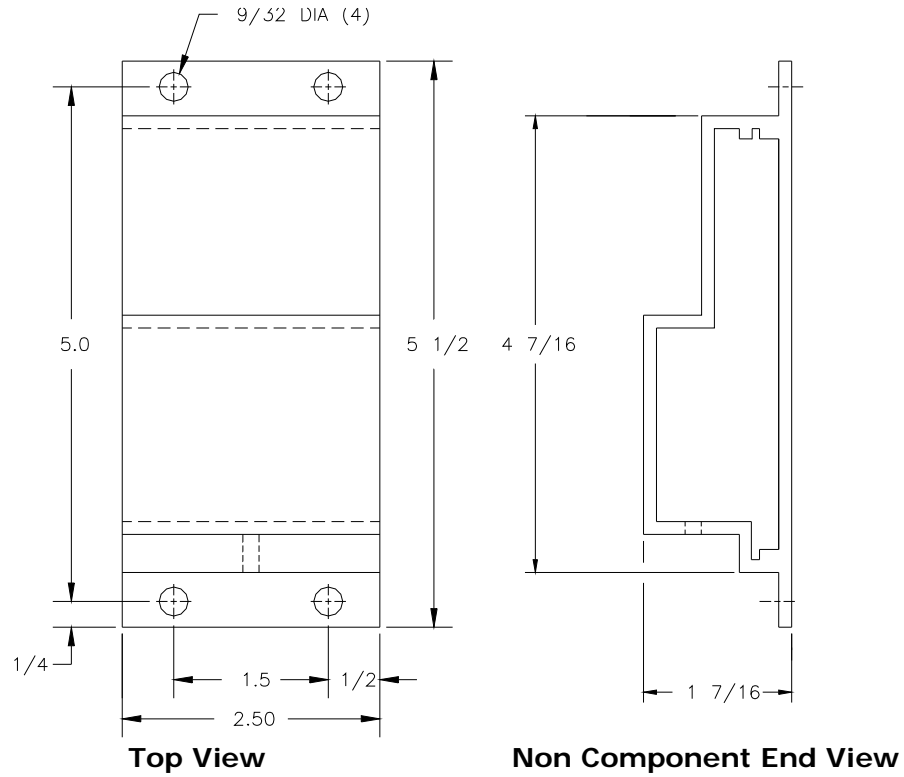

Figure 3-6. Positional ECM (dimensions in inches)

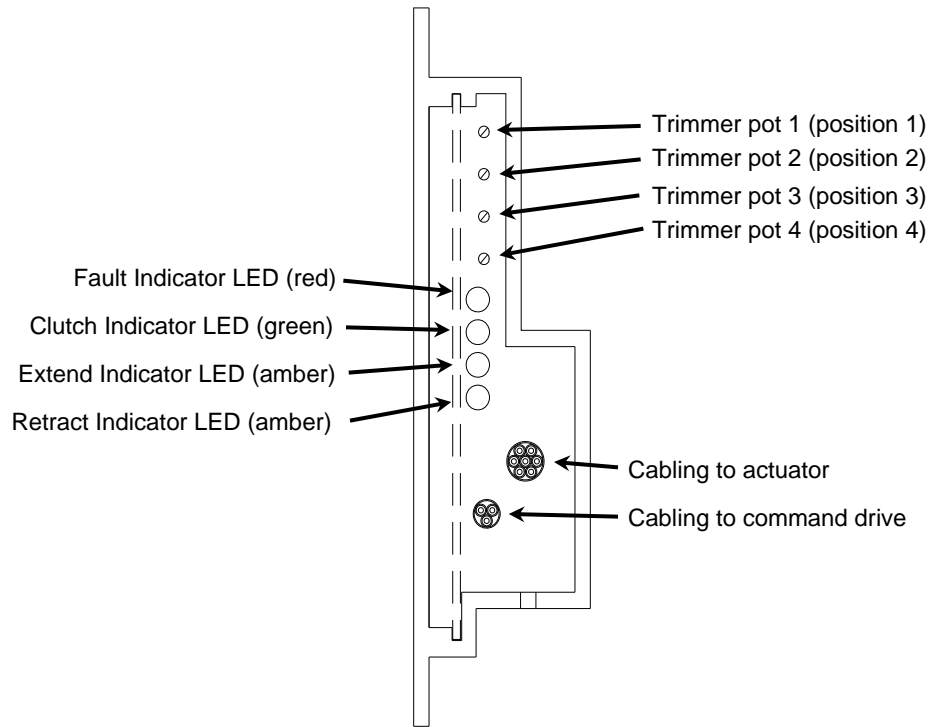

Figure 3-7. Positional ECM (component end view)

Joystick/Command Device

The command device in the ERC system is used by the operator to control the position of the actuator output rod. The electronic ECM compares the signal from the command device to the signal from the actuator feedback potentiometer and makes adjustments to the actuator rod position as needed.

For the Proportional System, the control portion of the command device will be a 10K ohm potentiometer. Potentiometer values other than 10K ohms can be used, however, system performance may be affected. Values less than 10K ohms will result in a reduced actuator rod stroke length.

If the command signal is a variable voltage input supplied to the Actus proportional controller, the control voltage must be not less than 1.9 VDC or more than 4.9 VDC (voltage outside these parameters will result in an error signal and the clutch and motor circuits will shut-off after five (5) seconds operation).



Note

Typically tolerance potentiometers (± 20 percent) have been used successfully in many applications—including foot pedal devices.

In the Five Position system, up to four command positions can be preset using the four trim potentiometers located on the ECM. The operator then uses a switch, or switches, to select one of the trim potentiometers to be used for the command signal. The ECM will then compare the input signal (voltage) from the operator selected trim potentiometer to the signal from the actuator feedback potentiometer. The ECM will then make any necessary adjustments to the actuator rod position.

Joysticks 310 Series

Characteristics/Parameters	Model	
	Single Axis	Multiple Axis
Rotational Movement	75°	50°
Command signal:	3 Terminal; 10K ohm potentiometer	
Temperature range:	-40°F (-40°C) to +158°F (70°C)	
Optional control features:	<ul style="list-style-type: none"> • Spring centering • Center detent • Auxiliary handle switch • Friction hold • Ball or grip type handle • Neutral switch 	

See figures 3-6 through 3-10 for command device control, interconnect, and dimensional data.

Chapter Four - SYSTEM INSTALLATION AND DESIGN

Actuator

The following guidelines should be used for installing the actuator:

Caution



When installing, failure to allow for full movement of actuator output rod, or the introduction of side load to the output rod, will dramatically shorten actuator life.

Usage of a vice grip or similar tool on the output rod could damage the surface of the rod. Use only the wrench flats on the rod end as a gripping point for tightening jam nut.

Do not rotate rod.

- Actuators should be mounted with the rod horizontal or down. Avoid mounting actuator with rod end up and power connector above actuator.
- Take care to insure the rod moves freely when connected to the load.
- If the load moves through an arc (for example, throttle or pump control lever) be sure actuator can pivot or the linkage is slotted to allow freedom of motion.
- Whenever possible, it is best to use a swivel adapter or similar device on the rod end to prevent side load.
- For best results, setup the linkage such that the output rod movement approaches a full three-inch stroke. This will provide the best accuracy response for the system.
- For your convenience, Actus offers mounting hardware for both actuators. See Chapter 6 "Troubleshooting" for information on how to contact Actus. Also see figures 4-1, 4-2 and 4-3 for dimensional information.
- When space is limited, the actuator may be mounted remotely and connected to the load with a cable.
- Although the actuator is designed and built to work in harsh environments, it is not intended for submersible operations.
- Output force rated at 30 lbs. or 60 lbs., are holding forces. Actuators are capable of developing a minimum of 90 lbs. and 150 lbs. force. Consideration should be made to protect linkages, levers, connecting hardware and the operator during set-up and operation.

Caution



When using the ERC system with a hydrostatic pump or hydraulic valve, be sure the spring centering device has enough force to center the system when the clutch is disengaged. If there is no spring centering device on the pump, you must provide one. Minimum spring forces are 7 lbs for 722 series actuator and 10 lbs for the 723 series.

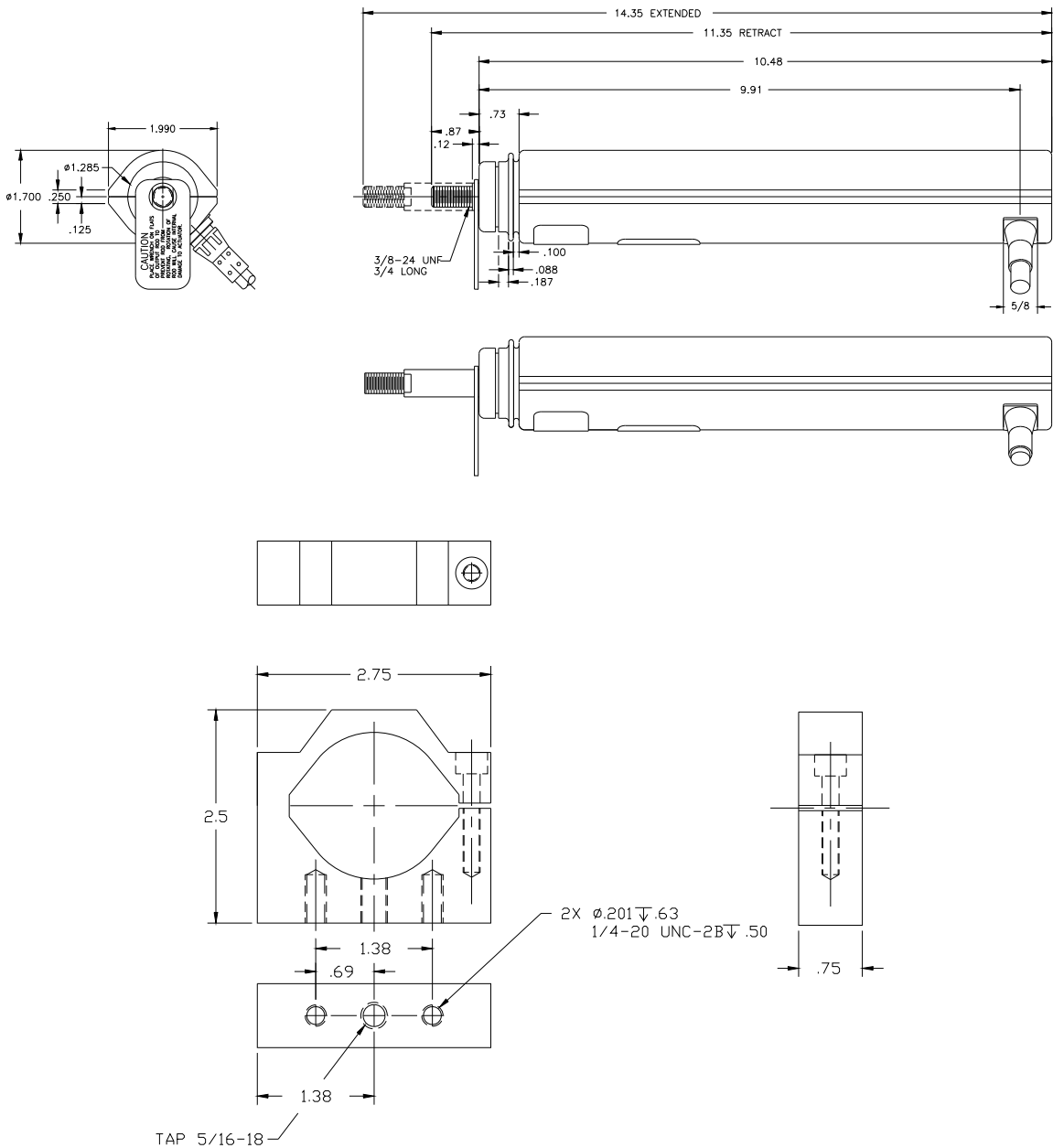

Figure 4-1. 722 Series Actuator with Mounting Clamp (dimension in inches)

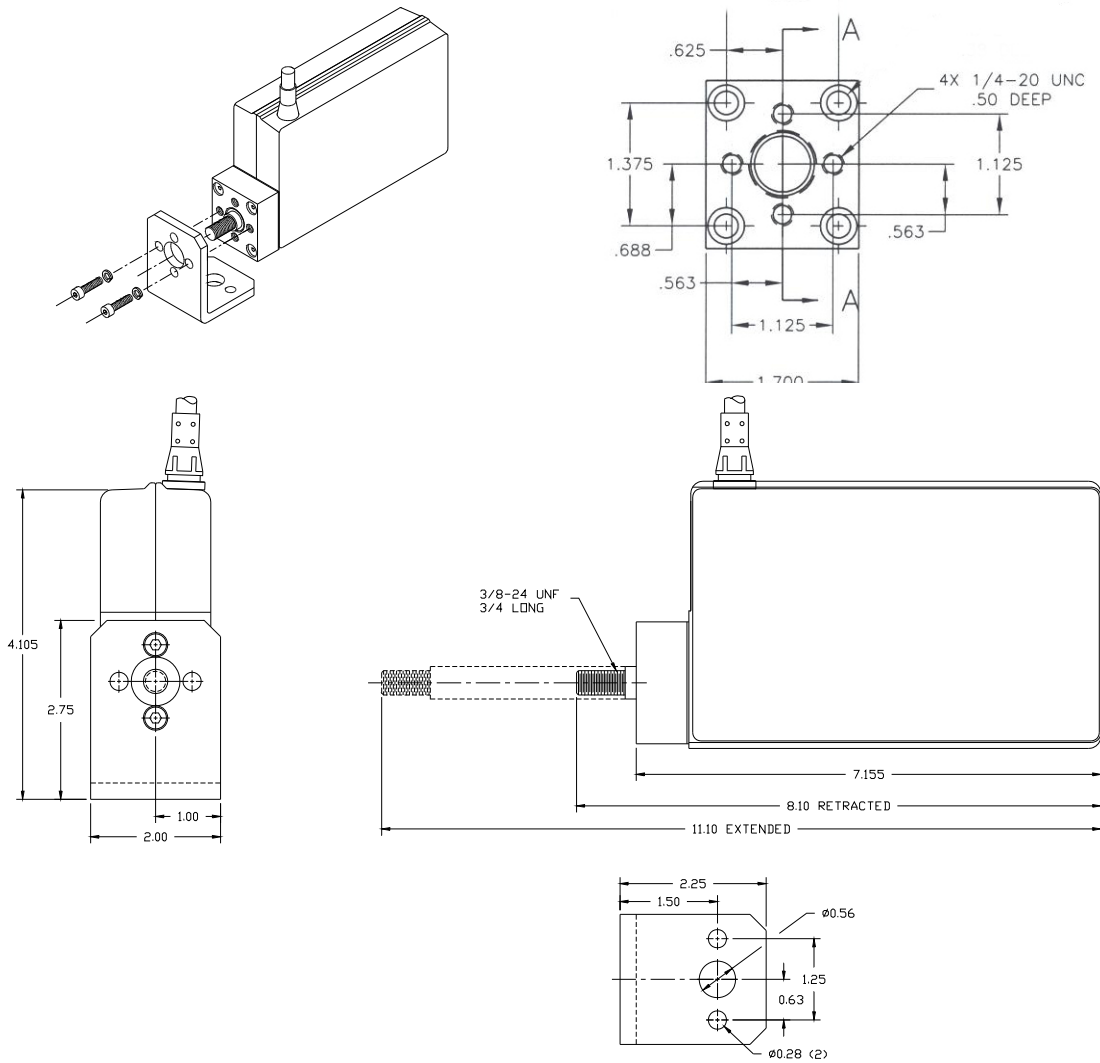
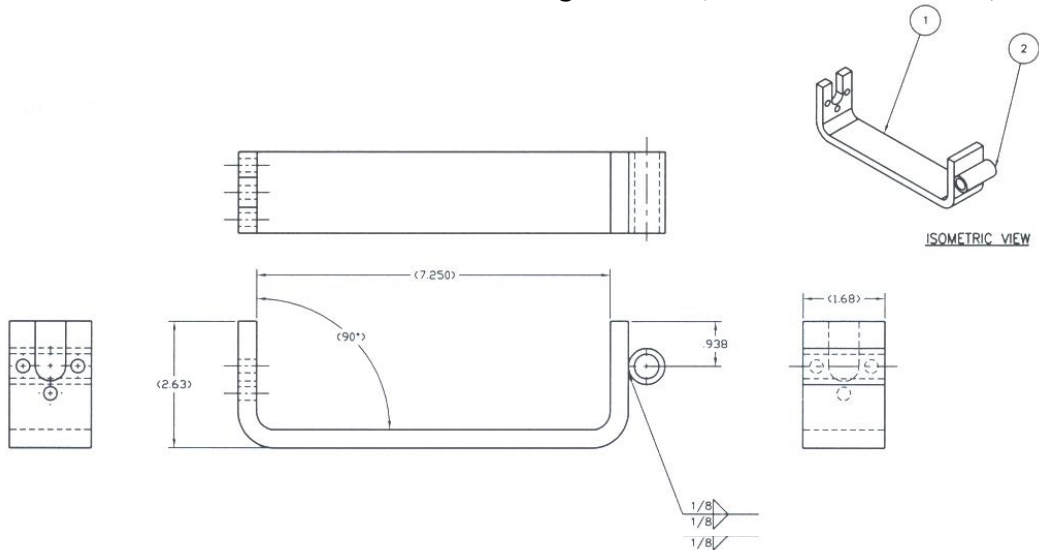

Figure 4-2. 723 Series Actuator with Mounting Bracket (dimensions in inches)



4-3. 723 Series ERC Trunion Mounting Bracket (dimensions in inches)

Electronic Control Module (ECM)

The following guidelines should be used for installing the ECM:

Caution



The positional ECM contains components, which may be affected by excessive vibration, resulting in erratic behavior and shorten operating life. Do not mount directly on an engine or machine element, which will experience high vibration. Shock mounts or vibration dampeners should be used for high vibration applications.



Note

A 12 Vdc nominal power source capable of supplying a minimum of 75 watts continuous output (150-watt surge) is required to power the system.

- Mount the ECM as close to the actuator as is practical.
- Mount the ECM so that the trim pots and LEDs are easily accessible for adjustment. If possible, mount vertically such that water cannot pool around the trim pots.
- If at all possible, mount the ECM in sight of actuator to simplify making adjustments to the trim pot.
- Although the ECM is potted for protection against the elements, it is still best to mount it in a protected area, away from heat, moisture and flying debris.
- Connect the +12Vdc line to the positive terminal on the battery using minimum 18 gauge wire. Fuse this line with a 5 amp automotive type fuse (see figures 7-1 and 7-2).
- It is important to ground the ECM directly to the negative terminal of the battery or power source. Failure to do so could cause a voltage drop or noise in the power loop resulting in reduced performance.

Joystick—Foot Pedal/Command Device

The following guidelines should be used for installing the Joystick/Command Device:

- Typically, joysticks and foot pedals will be mounted in the cutout of a panel, floorboard, or control pedestal. Be sure device is fastened firmly to its mounting surface.
- Joystick/command devices can be used successfully at distances up to 50 feet from the controller. Connecting cable should be 3 wire, 18 gauge shielded.
- The joystick/command device for the positional controller is usually a selector switch or switches (Double Pole, Double Throw—DPDT). If only three positions are required, only one 3-position switch is needed.
- See figures 7-1 and 7-2 for wiring details.
- It is possible to use more than one command device and control a single actuator from different stations. When designing for multiple control stations, a means of selecting which device is in control (selector, switch, relays, etc.)

must be provided (see Chapter 9 "Applications" for additional information).

- It is important to orient the joystick/command device properly to ensure that the actuator rod travels in the desired direction. With unit wired as shown in figure 7-2, check the orientation. If opposite orientation is desired, switch black and red joystick wires.
- If the command signal is a variable voltage input supplied to the Actus proportional controller, the control voltage must be not less than 1.9 VDC or more than 4.9 VDC. (Voltage outside these parameters will result in an error signal and the clutch and motor circuits will shut-off after five (5) seconds operation.)
- When using an ECM, other than the Actus design, it is important to incorporate safety features to protect the operator, equipment and actuator.

Chapter Five - SYSTEM SETUP

Proportional System

Setting Extend and Retract Positions

Four LEDs are located in the ECM to aid in setup and troubleshooting (see figure 5-1). See also table below.

LED (color)	Description
FAULT Indicator (red)	Turns on if one of the following conditions occur: <ul style="list-style-type: none"> • Low voltage (system voltage less than 10.3 Vdc) • Broken wire • Out-of-position error • End point crossover
CLUTCH Indicator (green)	Turns on whenever the clutch is engaged.
EXTEND Indicator (amber)	Turns on when the controller is driving the actuator rod to extend position. Turns off when extend position is reached.
RETRACT Indicator (amber)	Turns on when the controller is driving the actuator rod to retract position Turns off when retract position is reached.

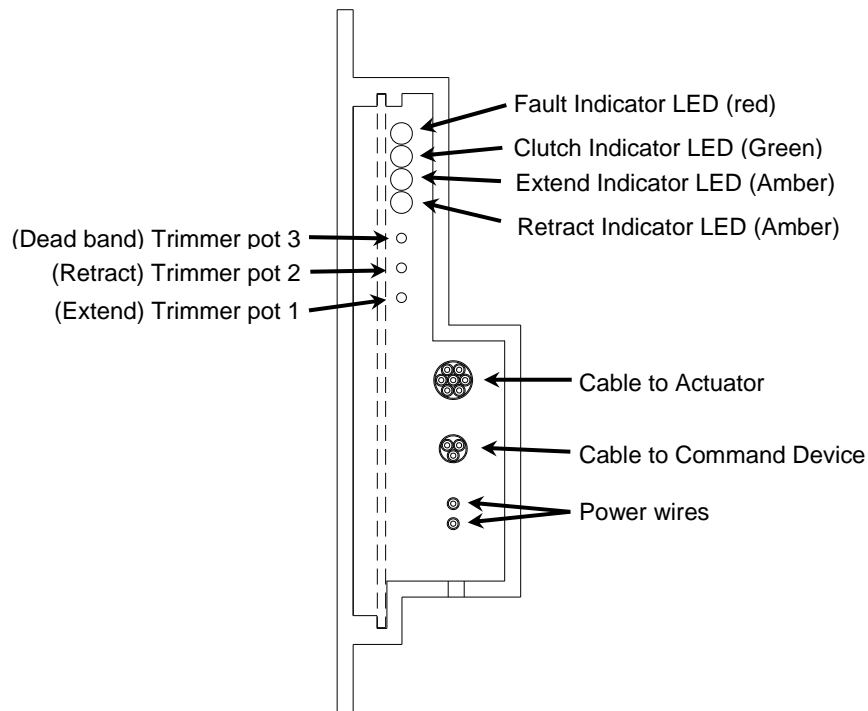

Figure 5-1. Proportional ECM (component end view)

Caution



Depending on your application, the ECM may drive the actuator beyond the physical limits. If the ECM has been set to drive the actuator beyond its physical limits, the clutch will release after five seconds, power will be cut off to the motor, and the actuator rod will return to the “float” state. This prevents damage to the actuator and the equipment on which it is installed.

To set the extend position:

It is important to understand that the center position (for example, neutral position in a hydrostatic transmission or valve application) is one half the distance between the extend and retract set points. In order to find the correct center position it may be necessary to repeat this procedure more than once. By lengthening and/or shortening the extend or retract settings, the stroke length window is moved along the rod travel. The center position cannot be varied if the actuator is being used at the full three inches of stroke.

The Extend and Retract trim pots are interactive. Changing the retract potentiometer may affect the full extend position as well as the retract. For this reason, you may need to go through *Setting the Extend Position* and *Setting the Retract Position* procedure two or three times to achieve the exact travel desired.



Note

It is best to observe rod position when setting the ECM. If this is not possible, you can set positions by observing only the LEDs.

1. Turn system on.
2. Move the joystick/command device to the full extend position.

Caution



Continuing to turn the Extend trim pot CW beyond the desired maximum position will cause the rod to extend until it reaches the end of the stroke or a mechanical stop caused by the external load. When this happens, the rod will stop moving, the Extend LED will flicker or turn solid amber and the clutch may start to slip. When this happens, rotate the Extend trim pot CCW until the Extend LED goes out. If the system is not adjusted back into the usable stroke range of the actuator (i.e., Extend pot rotated CCW) within five seconds, the clutch will release, the motor drive will shut off and the Fault LED will turn on. By continuing to adjust the trim pot until the command signal matches the feedback signal, the clutch will re-engage and clear the fault.

3. Turn Extend trim pot—see figure 5-1 (CW to extend) until you reach the desired maximum extend position. Observe the amber Extend LED (see figure 5-1). It must be off at the maximum extend point.

To set the retract position:

It is important to understand that the center position (for example, neutral position in a hydrostatic transmission or valve application) is one half the distance between the extend and retract set points. In order to find the correct center position it may be necessary to repeat this procedure more than once. By lengthening and/or shortening the extend or retract settings, the stroke length window is moved along the rod travel. The center position cannot be varied if the actuator is being used at the full three inches of stroke.

1. Move the joystick/command device to full retract position.
2. Turn Retract trim pot—see figure 5-1 (CCW to retract) until it reaches desired retract position.

Caution  **Continuing to turn the Retract trim pot CCW beyond the desired retract position will cause the rod to retract until it reaches the beginning of the stroke or a mechanical stop caused by the external load. When this happens, the rod will stop moving, the Retract LED will flicker or turn solid amber and the clutch may start to slip. When this happens, rotate the Retract trim pot CW until the Retract LED goes out. If the system is not adjusted back into the usable stroke range of the actuator (i.e., Retract pot rotated CW) within five seconds, the clutch will release, the motor drive will shut off and the Fault LED will turn on. By continuing to adjust the trim pot until the command signal matches the feedback signal, the clutch will re-engage and clear the fault.**

3. Observe the amber Retract LED (see figure 5-1). It must be off at the minimum retract point.

Deadband Adjustment

The deadband adjustment is a control signal sensitivity setting. The purpose of the deadband control is to dampen the actuator response to a command input change. A sensitive setting will result in immediate movement of the actuator output rod when there is a change in the command signal and result in some overshoot. A less sensitive setting will result in a slight delay in the actuator output rod movement with a change in command signal but result in less overshoot. It is recommended that the ECM should be set to the most sensitive position possible, without experiencing actuator output rod “hunting”. Use trimmer pot 3 (deadband adjust)—Figure 5-1 for making deadband adjustment. Turn CW for a more sensitive response.



Note

When making deadband adjustments, and neutral is sensitive and hard to hold (for example, on a hydrostatic transmission) it may be advisable to incorporate circuitry (a neutral switch) which cuts power to the actuator clutch when the joystick is in the neutral position. This will allow the spring centering device on the pump or valve to ensure a neutral position.

It may also be possible to incorporate special valving in the hydrostatic circuit to create a wider deadband.

Positional system

Setting positions

Four LEDs are located on the ECM to aid in setup and troubleshooting (see figure 5-2). See also table below.

LED (color)	Description
FAULT Indicator (red)	Turns on if one of the following conditions occur: <ul style="list-style-type: none"> • Low voltage (system voltage less than 10.3 Vdc) • Broken wire • Out-of-position error
CLUTCH Indicator (green)	Turns on whenever the clutch is engaged.
EXTEND Indicator (amber)	Turns on when the controller is driving the actuator rod to the extend position. Turns off when extend position is reached.
RETRACT Indicator (amber)	Turns on when the controller is driving the actuator rod to the retract position. Turns off when retract position is reached.

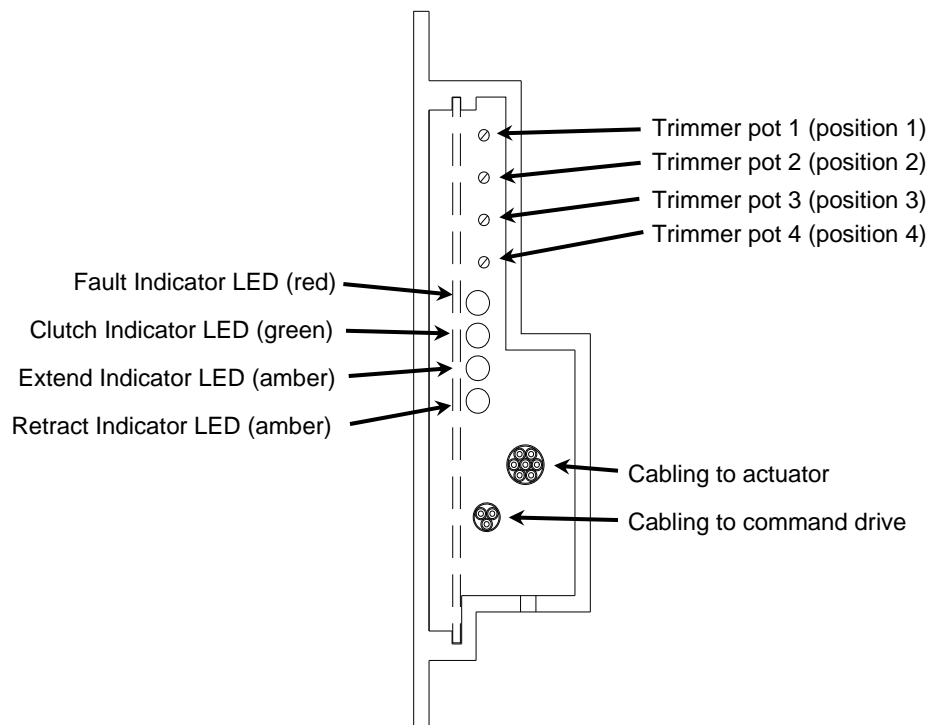



Figure 5-2. Positional ECM (component end view)

Caution  Depending on your application, the ECM may drive the actuator beyond the physical limits. If the ECM has been set to drive the actuator beyond its physical limits, the clutch will release after five seconds,

power will be cut off to the motor, and the actuator rod will return to the “float” state. This prevents damage to the actuator and the equipment on which it is installed. If the rod is moving to full extend or retract for five seconds and then returning to neutral, the selected trim pot must be readjusted to within the acceptable range. If the rod is extending before failure, the selected trim pot must be rotated CW. If the rod is retracting before failure, the selected trim pot must be rotated CCW.

One of the five positions on the positional system is the neutral or “float” position. In this position the actuator rod has no holding force, the output rod is floating because no power is being applied to the ECM. No adjustments of the ECM are needed to set this position, however, an external spring or other means must be used to return the actuator rod to a desired position.

The other four positions are set using the four trim pots mounted on the ECM. Use *Position Control Truth Table* in figure 5-3 to determine the input needed to select each position and associated trim pot. For example, +12 Vdc on both the white and green input wires will be associated with trim pot 4 as the command input.

Rotating the screw on the selected trim pot CCW will extend the rod.

Rotating the screw CW will retract the rod.

POSITION CONTROL TRUTH TABLE				
CONTROL WIRING				ACTUATOR POSITION
BLACK	RED	WHITE	GREEN	
GND	OFF	X	X	OFF POSITION (FREEWHEEL)
GND	+12 VDC	OFF	OFF	POSITION 1 (SEE ADJUSTMENTS)
GND	+12 VDC	+12 VDC	OFF	POSITION 2 " "
GND	+12 VDC	OFF	+12 VDC	POSITION 3 " "
GND	+12 VDC	+12 VDC	+12 VDC	POSITION 4 " "

GND = POWER SUPPLY OR BATTERY GROUND
 OFF = GROUND OR OPEN CIRCUIT
 X = DON'T CARE
 +12 VDC = +12 VOLT POWER SUPPLY OR BATTERY SYSTEM,
 VIA A 5 AMP FUSE OR CIRCUIT BREAKER

TRIMMER ADJUSTMENTS

- 1 - POSITION 1 CW=RETRACT
- 2 - POSITION 2 CW=RETRACT
- 3 - POSITION 3 CW=RETRACT
- 4 - POSITION 4 CW=RETRACT

Figure 5-3. Positional ECM Position Control Truth Table

A small adjustment to a trim pot will change the “electronic” position of the system. However, due to the overall dynamics of the system, the output rod may not change positions. Therefore, a small dead-band window (similar to Proportional ECM but not adjustable) exists in the electronics and all positions should be checked to verify that the actuator rod returns to the desired position. If not, make small adjustments to the selected trim pot, toggle between another trim pot and verify the rod is in the desired position.

Chapter Six - TROUBLESHOOTING

Technical Support

If you cannot correct a problem, do the following before contacting your Actus system specialist:

- Return to the beginning of the entire installation process and review the steps. Be sure that you followed all of the instructions provided.
- If you reviewed the installation instructions and you are still encountering a problem, document:
 - The specific problem and the steps taken to solve the problem.
 - When and under what conditions the problem started—please be as specific as possible
- If the attempts to correct the problem fail, call or e-mail Actus. Technical Support or Customer Service at the address and telephone numbers listed in Customer Service section.

Customer Service

North America customers call Actus at:

Main Telephone: **(651) 487-8716**

Fax questions to: **(651) 487-4173**

Web Site: **www.actusinc.com**

Web Support: **support@actusinc.com**

Electric Remote Control Troubleshooting

The troubleshooting chapter is divided into four areas:

- Positional System Evaluation
- Proportional System Evaluation
- Actuator Evaluation
- Command Device Evaluation

Positional System Evaluation

The most efficient way to troubleshoot the Electric Remote Control (ERC) system is to make use of the Light Emitting Diodes (LED)s on the face of the ECM (see figure 6-1). The vast majority of problem conditions can be analyzed by monitoring the LEDs and the sequence they come on or go off when power is applied to the system. The following table lists the (LED)s and their functions, that can be used for troubleshooting purposes:

LED (color)	Description
FAULT Indicator(red)	Turns on if one of the following conditions occur: <ul style="list-style-type: none"> • Low voltage (System voltage less than 10.3 Vdc) • Broken wire • Out-of-position error
CLUTCH Indicator(green)	Turns on whenever the clutch is engaged.
EXTEND Indicator(amber)	Turns on when the controller is driving the actuator rod to the extend position. Turns off when extend position is reached.
RETRACT Indicator(amber)	Turns on when the controller is driving the actuator rod to the retract position. Turns off when retract position is reached.

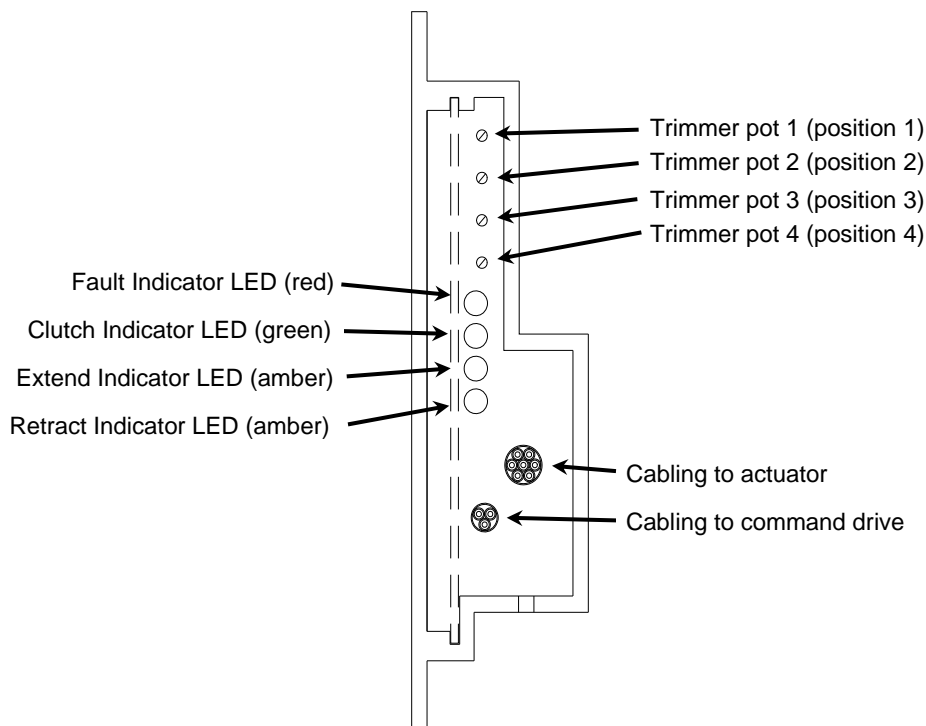

Figure 6-1. Positional Controller (component end view)

In the following correction procedure, all voltage measurements must be taken within five seconds after turning power on. After the Red LED turns on (after five second), the motor power will be cut off by the controller, and the voltage across the red and black will be zero Vdc. If measurement cannot be made within five seconds, recycle power and try again.

The following table lists the problem, probable cause, and corrective action associated with troubleshooting the positional controller. Observe the problem conditions and then see problem condition in the table to find out the probable cause and what corrective action is needed to resolve problem.

Problem Condition	Probable Cause	Corrective Action
No LEDs are lit when power is applied to system	Faulty connection between power source and ECM	Check power cables. Replace or repair as necessary
	Faulty power source	Check power source. Power source should have a voltage of 11.5 to 16.0 Vdc and 75 watts continuous output (150 watts surge). Replace or repair as necessary.
	Faulty LEDs or ECM	Replace ECM
Power supplied: <ul style="list-style-type: none"> • Red Fault LED lights immediately • No other LEDs are lit 	Faulty connection between ECM and actuator	Check orange, brown and white wires, for loose or broken condition. Repair or replace as necessary.
Power supplied: <ul style="list-style-type: none"> • Green Clutch LED is lit • Actuator does not move when toggling between two positions • Red Fault LED does not light 	The two position trimmer pots are set to move actuator to the same position	Turn one of the trimmer pots—see figure 6-1 several turns (CW or CCW), toggle position and observe actuator rod movement. It may still be necessary to adjust the actuator rod to the proper position. See Chapter 5 “System Setup”.
	Faulty input device wiring	Check wiring between ECM and input device (see figure 7-1). Repair or replace as necessary.
	Faulty ECM	Replace ECM.

Problem Condition	Probable Cause	Corrective Action
Power supplied: <ul style="list-style-type: none"> • Command device switched to desired position • Actuator motor running • Either Amber Extend or Retract LED is lit for 5 seconds • Green Clutch LED is lit for 5 seconds • Actuator rod does not move • Red Fault LED comes on after 5 seconds 	Faulty connection between ERC components	Check wiring—black and red (motor); green and blue (clutch). Repair or replace as necessary.
	Faulty actuator	See <i>Actuator Evaluation</i> in this chapter.
	Faulty ECM	Replace ECM.
Power supplied: <ul style="list-style-type: none"> • Green Clutch LED is lit • After approximately 45 seconds, green Clutch LED turns off • Red Fault LED is lit 	Low system voltage	Check power source. Power source should have a voltage of 11.5 to 16.0 Vdc and 75 watts continuous output (150 watts surge). Replace or repair as necessary.

Proportional System Evaluation

The most efficient way to troubleshoot the ERC system is to make use of the Light Emitting Diodes (LED)s on the face of the ECM (see figure 6-2). The vast majority of problem conditions can be analyzed by monitoring the LEDs and the sequence they come on or go off when power is applied to the system. The following table lists the (LED)s and their functions, that can be used for troubleshooting purposes:

LED (color)	Description
FAULT Indicator(red)	Turns on if one of the following conditions occur: <ul style="list-style-type: none"> • Low voltage (System voltage less than 10.3 Vdc) • Broken wire • Out-of-position error • End point crossover
CLUTCH Indicator(green)	Turns on whenever the clutch is engaged.
EXTEND Indicator(amber)	Turns on when the controller is driving the actuator rod to the extend position. Turns off when extend position is reached.
RETRACT Indicator(amber)	Turns on when the controller is driving the actuator rod to the retract position. Turns off when retract position is reached.

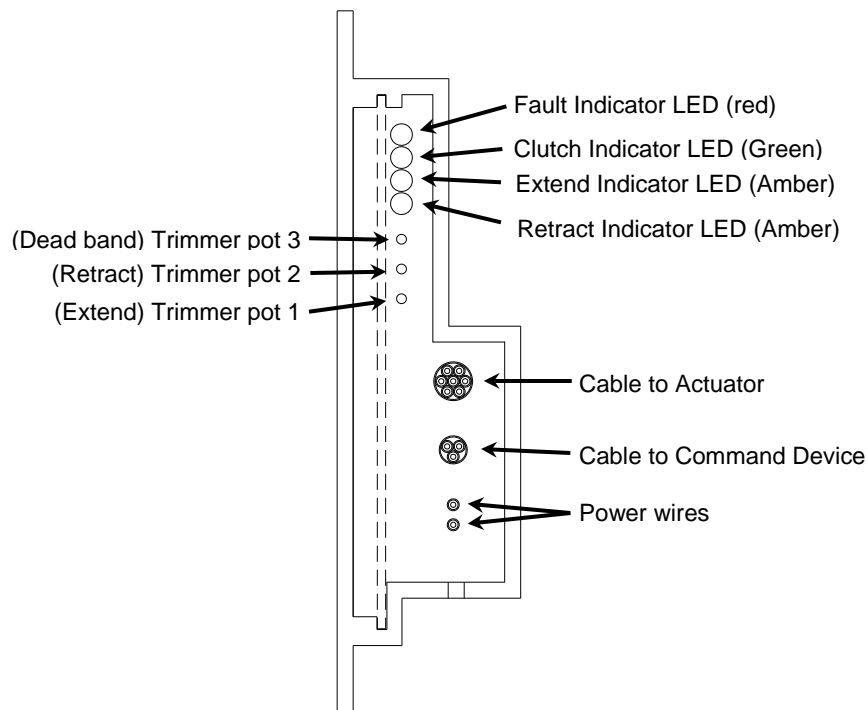

Figure 6-2. Proportional ECM (component end view)

In the following correction procedure all voltage measurements must be taken within five seconds after turning power on. After the Fault LED turns on (after five second), the motor power will be cut off by the controller, and the voltage across the red and black will be zero Vdc. If measurement cannot be made within five seconds, recycle power and try again.

The following table lists the problem, probable cause, and corrective action associated with troubleshooting the proportional controller. Observe the problem conditions and then see problem situation in the table to find out the probable cause and what corrective action is needed to resolve problem.

Problem condition(s)	Probable Cause	Corrective Action
No LEDs lit when power to system is applied.	Faulty connection between power source and ECM	Check power cables (red/white and black/white). Replace or repair as necessary
	Faulty power source	Check power source. Power source should have a voltage of 11.5 to 16.0 Vdc and 75 watts continuous output (150 watts surge). Replace or repair as necessary.
	Faulty LEDs or ECM	Replace ECM
Power supplied: <ul style="list-style-type: none"> • Red Fault LED lights immediately • No other LEDs are lit 	Faulty connection between ECM and actuator	Check orange, brown and white wires for loose or broken condition. Repair or replace as necessary.
	Faulty feedback potentiometer in the actuator	See <i>Actuator Evaluation</i> in this chapter.
	Faulty connection between ECM and command device	Check red, white and black wires for loose or broken condition. Repair or replace as necessary.
	Faulty command device	Replace command device.
	Extend/retract position crossover misadjusted	Turn Extend trim pot CW (see figure 6-2) one turn, turn retract trim pot CCW one turn, recycle power and repeat process until only Clutch LED remain on after 5 seconds. It may still be necessary to reset the actuator rod to the proper retract and extend positions. See Chapter 5 "System Setup".

Problem condition(s)	Probable Cause	Corrective Action
Power supplied: <ul style="list-style-type: none"> • Command device set for minimum retract position • Actuator rod retracts to beginning of stroke • Amber Retract and Green Clutch LEDs are lit for 5 seconds • Red Fault LED lights after 5 seconds 	Retract trim pot set beyond minimum retract position	Turn Retract trim pot (see figure 6-2) CW one turn, cycle power, and repeat process until only green Clutch LED remains on after 5 seconds. It may still be necessary to reset the actuator rod to the proper retract position. See Chapter 5 "System Setup".
	Faulty command device	See <i>Command Device Evaluation</i> in this chapter.
Power supplied: <ul style="list-style-type: none"> • Command device set for maximum extend position • Actuator rod extends to end of stroke • Amber Extend and Green Clutch LEDs are lit for 5 seconds • Red Fault LED comes on after 5 seconds 	Extend trim pot set beyond maximum extend position	Turn Extend trim pot (see figure 6-2) CCW one turn, cycle power, and repeat process until only green Clutch LED remains on after 5 seconds. It may still be necessary to reset the actuator rod to the proper extend position. See Chapter 5 "System Setup".
	Faulty command device	See <i>Command Device Evaluation</i> in this chapter.
Power supplied: <ul style="list-style-type: none"> • Command device set to extend or retract • Actuator motor running • Either Amber Extend or Retract LED is lit for 5 seconds (depending on command device position) • Green Clutch LED is lit for 5 seconds • Actuator rod does not move • Red Fault LED comes on after 5 seconds 	Faulty connection between ERC components	Check wiring between ERC components (see figure 7-2). Repair or replace as necessary.
	Faulty actuator	See <i>Actuator Evaluation</i> in this chapter.
	Faulty command device	See <i>Command Device Evaluation</i> in this chapter.
	Faulty ECM	Replace ECM.

Actuator Evaluation

When performing the actuator evaluation, follow the steps listed below:

1. Disconnect actuator from the system.
2. Connect 12 Vdc power source positive and ground to the red and black actuator wires, respectively. The current should be approximately 0.6 amps. If not, the motor is faulty. Reverse the power and ground connections on the red and black actuator wires. If current is not 0.6 amps, the motor is faulty.
3. Connect 12 Vdc power source positive and ground to the blue and green actuator wires, respectively. Clutch should engage and rod should not be moveable as indicated by applying nominal force to push or pull rod. If the rod can be moved, the clutch is faulty.
4. Disconnect the actuator from the power source.
5. Attach an ohmmeter to the brown and orange actuator potentiometer wires. The ohmmeter should read 8-12K ohms. If not, the actuator potentiometer is faulty.
6. Attach an ohmmeter to the brown and white actuator potentiometer wires. Move the actuator rod through its full stroke (zero to three inches) by slowly pushing or pulling the rod. The ohmmeter reading should vary continuously from zero to 10k ohms as the rod is moved through its stroke. If at any time during the stroke the ohmmeter reads an infinite resistance value (i.e., an open circuit), the feedback potentiometer in the actuator is faulty.

Command Device Evaluation

When performing the command device evaluation, follow the steps listed below:

1. Disconnect the command device (i.e., joystick, foot pedal, etc.) from the system.
2. Connect an ohmmeter between the POT+ and POT- wires on the command device. The ohmmeter should read approximately 10K ohms. If not, the command device potentiometer is faulty.
3. Attach an ohmmeter between the POT- and POT wiper wires. Move the command device through its full stroke. The ohmmeter reading should vary continuously from zero to 10k ohms as the command device is moved through its stroke. If at any time during the stroke the ohmmeter reads an infinite resistance value (i.e., an open circuit), the potentiometer in the command device is faulty.

Chapter Seven - WIRING DIAGRAMS

This chapter contains the Electric Remote Control (ERC) system interconnect wiring diagrams.

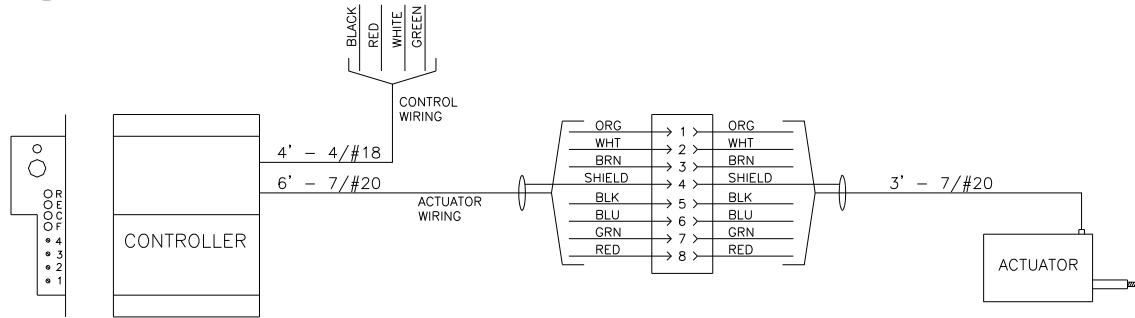

2. TERMINATE CONTROL WIRING AS INDICATED IN THE POSITION CONTROL TRUTH TABLE BELOW.
1. CONNECTORS ARE OPTIONAL. STANDARD SYSTEM CONSISTS OF PIGTAILS ONLY. WHEN INSTALLING CONNECTORS, SHIELD MUST BE INCLUDED IN CONNECTOR.

TRIMMER ADJUSTMENTS

- 1 - POSITION 1 CW=RETRACT
- 2 - POSITION 2 CW=RETRACT
- 3 - POSITION 3 CW=RETRACT
- 4 - POSITION 4 CW=RETRACT

LED INDICATORS

- R - RETRACT INDICATOR (AMBER)
- E - EXTEND INDICATOR (AMBER)
- C - CLUTCH INDICATOR (GREEN)
- F - FAILURE INDICATOR (RED)

POSITION CONTROL TRUTH TABLE				
CONTROL WIRING				ACTUATOR POSITION
BLACK	RED	WHITE	GREEN	
GND	OFF	X	X	OFF POSITION (FREEWHEEL)
GND	+12 VDC	OFF	OFF	POSITION 1 (SEE ADJUSTMENTS)
GND	+12 VDC	+12 VDC	OFF	POSITION 2 " "
GND	+12 VDC	OFF	+12 VDC	POSITION 3 " "
GND	+12 VDC	+12 VDC	+12 VDC	POSITION 4 " "

GND = POWER SUPPLY OR BATTERY GROUND
 OFF = GROUND OR OPEN CIRCUIT
 X = DON'T CARE
 +12 VDC = +12 VOLT POWER SUPPLY OR BATTERY SYSTEM,
 VIA A 5 AMP FUSE OR CIRCUIT BREAKER

Figure 7-1. Positional System Wiring Diagram with Position Control Truth Table

Actuator Wire Code

- Black & Red – Motor
- Blue and Green – Clutch
- Brown/Orange/White** - Potentiometer
- Clear/Braided – Shield
- **White wire is the wiper (variable)

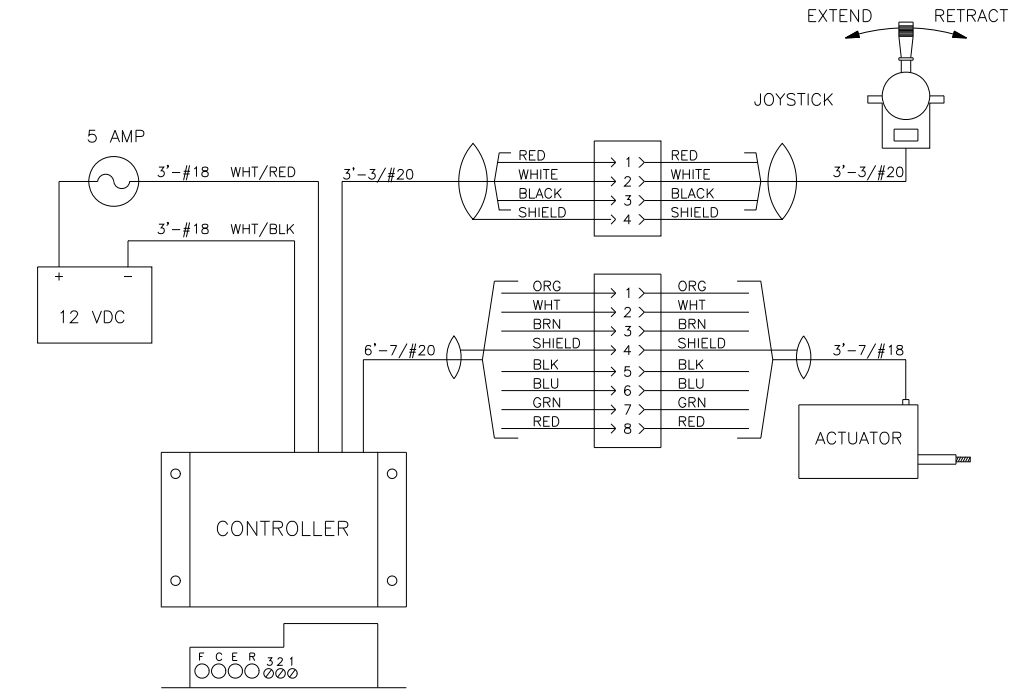

LED INDICATORS

- R - RETRACT INDICATOR (AMBER)
- E - EXTEND INDICATOR (AMBER)
- C - CLUTCH INDICATOR (GREEN)
- F - FAILURE INDICATOR (RED)

TRIMMER ADJUSTMENTS

- 1 - EXTEND POSITION CW=EXTEND
- 2 - RETRACT POSITION CCW=RETRACT
- 3 - DEADBAND CW=MORE SENSITIVE

CONNECTORS ARE OPTIONAL. STANDARD SYSTEM CONSISTS OF PIGTAILS ONLY.
 FUSED 12 VDC IS USUALLY ROUTED THROUGH A KEY SWITCH TYPE INPUT.

CALIBRATION PROCEDURE

1. MOUNT ACTUATOR ACCORDING TO APPLICATION.
2. WIRE SYSTEM AS SHOWN.
3. SET JOYSTICK TO FULL EXTEND POSITION. ADJUST EXTEND POSITION TRIMMER UNTIL THE ACTUATOR IS IN THE FULL EXTEND POSITION.
 NOTE - MOUNT THE JOYSTICK SO THE MOTION OF THE JOYSTICK (SEE ARROWS ON DRAWING) MATCH THE ACTUATOR MOTION. IF THIS IS NOT POSSIBLE, SWAP THE RED AND BLACK WIRES TO THE JOYSTICK.
4. SET JOYSTICK TO FULL RETRACT POSITION. ADJUST RETRACT POSITION TRIMMER UNTIL THE ACTUATOR IS IN THE FULL RETRACT POSITION.
5. ADJUST DEADBAND FOR DESIRED JOYSTICK SENSITIVITY WHILE ENSURING STABLE OPERATION. MOST APPLICATIONS WILL REQUIRE THE MOST SENSITIVITY POSSIBLE.
6. RECHECK STEPS 3 AND 4 AS NECESSARY.

Figure 7-2. Proportional System Wiring Diagram

Actuator Wire Code

- Black & Red – Motor
- Blue and Green – Clutch
- Brown/Orange/White** - Potentiometer
- Clear/Braided – Shield
- **White wire is the wiper (variable)

Chapter Eight - WARRANTY

LIMITED WARRANTY

Industrial Products

Actus warrants that this product will be free from defects in material and workmanship for a period of one (1) year from the date of original purchase.

The above warranty does not apply to a product that has **not** been installed or maintained in accordance with Actus' instructions, been subjected to damage in an accident or abused during operation, or repaired, modified, or disassembled by persons other than Actus. The warranty is also void when Actus products are installed on a vehicle, engine or piece of equipment judged by Actus to be an inappropriate application of its product, or when Actus products are used with other industrial accessory products which in Actus judgment are incompatible with the Actus product or adversely effect its performance or durability.

Actus responsibility in respect to warranty claims is limited solely to repair or replacement, Actus option, of product found by Actus to be defective. Actus does not pay for labor charges connected with removal of a product deemed to be defective or with installation or replacement of repaired product, or for any other incidental or consequential damages. **There are no other warranties, express, statutory, or implied, including that of merchantability and of fitness for a particular purpose.**

To make a claim under this warranty, contact Actus at (651) 487-8716 giving a description of the product and requesting authorization to return it to the factory.

PLEASE DO NOT RETURN MERCHANDISE TO ACTUS UNTIL YOU RECEIVE A RETURN MATERIALS AUTHORIZATION (RMA) NUMBER. MATERIAL RETURNED TO ACTUS WITHOUT A VISIBLE RMA NUMBER IS SUBJECT TO REJECTION.

After receipt of an authorization number, the product should be returned, freight prepaid, to Actus Manufacturing, 245 East Roselawn Avenue, St. Paul, Minnesota, 55117-3908. If found to be defective, and if all return freight charges have been prepaid, Actus will repair or replace the product, at our option, and return it freight prepaid.

Actus Manufacturing
245 East Roselawn Avenue
St. Paul, MN 55117-3908
(651) 487-8716
(651) 487-4173

Chapter Nine - APPLICATIONS

Typical Applications

The following figures represent typical applications of the Electric Remote Control (ERC) system.

Throttle



Throttle—Positional with Switch Input

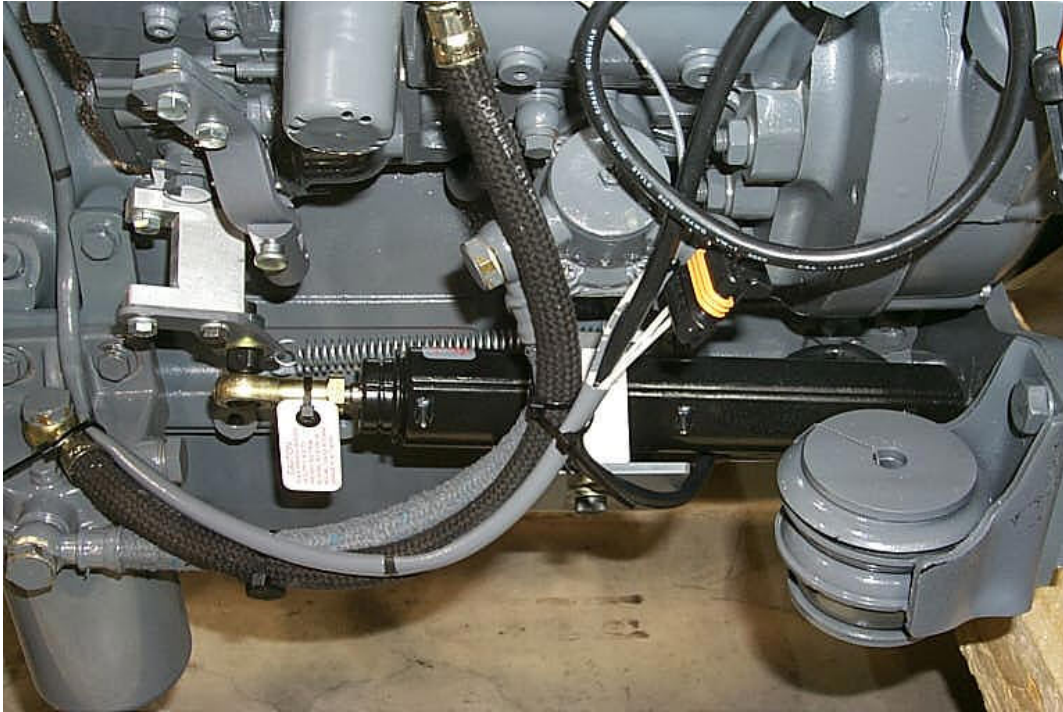

Throttle—Proportional with Command Pot Input

Valve

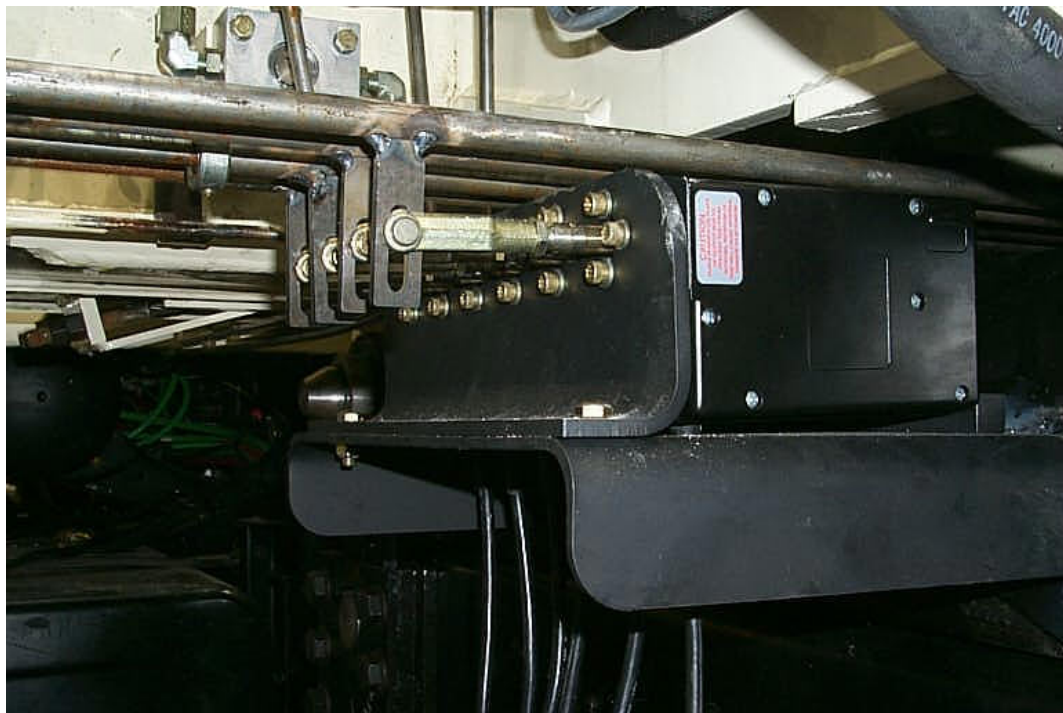

Stack Valve—Proportional (radio controlled)



Valve (three position)

Pump



Dual Pump (hydrostatic transmissions)

Chapter Ten - PARTS LIST

Electric Remote Control Parts List

The following table contains a description and Actus part number of all the Electric Remote Control (ERC) system elements:

Description	Actus part number
Actuator—series 722, tubular	722-0102
Actuator—series 723, doubleback	723-0102
Electronic Control Module (ECM)—Positional	771-0106
Electronic Control Module (ECM)—Proportional	771-0107
Command Device (Joystick)—Series 310 Single Axis, spring	310-0102
Command Device (Joystick)—Series 310, Single Axis,	310-0100
Command Device (Joystick)—Series 310, Dual Axis	310-0114
Mounting Clamp—for series 722, tubular actuator	001-2409
Mounting Bracket—for series 723, doubleback actuator	001-2411
Ball Joint, Actuator	027-0590
Connector, Electrical, for Actuator	001-1197
Connector, Electrical, for Controller	001-1195